



SCAN FOR
MORE INFO

ELECTRADROP-E



500 K CYCLES

STAINLESS MATERIAL

PREMIUM QUALITY



LOCINOX[®]

Let's make it better together

Motorised drop bolt with Fail Close functionality

Electric 24V drop bolt with 120 mm throw for safe locking of automated swing gates.

By securing your gate with an Electradrop you disburden the electric gate motors.



Find out more: locinox.com | help@locinox.com

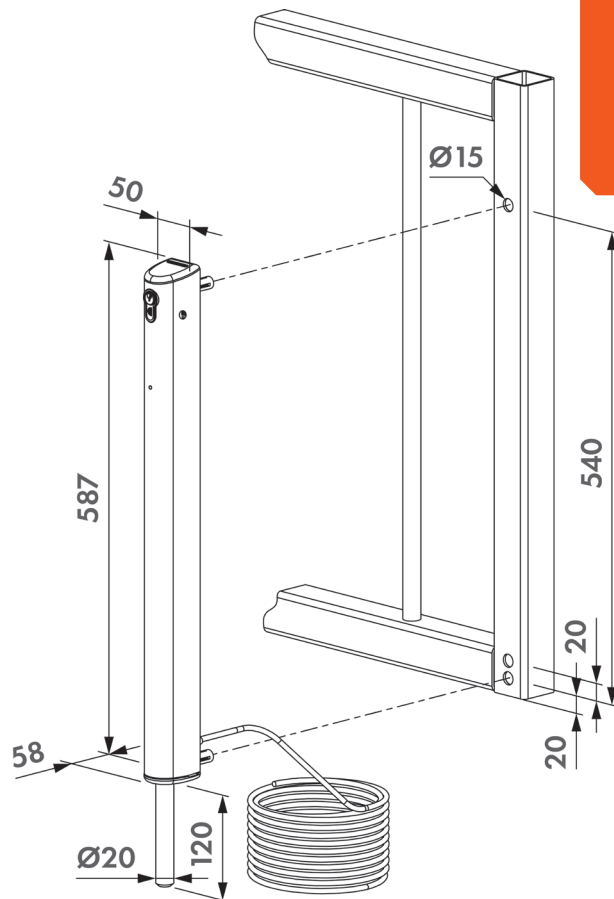

LOCINOX

Electradrop-E

Motorised drop bolt with
Fail Close functionality

What makes it special?

- Vandal-proof, powder coated aluminium housing
- To be connected to the warning light on automated gates (min 3 sec prewarning signal) or directly on the gate automation
- Automatic detection and memorisation of the continuous or pulse signal
- Mechanical release possible (by key) in case of emergency
- The integrated obstacle detection will automatically stop the drop bolt movement in case of overpressure to avoid injuries
- Throw: 120 mm
- Drop bolt diameter: 20 mm
- 5 m cable included
- Included: 3012-37-STD cylinder



Features

Configurations	ELECTRADROP-E ELECTRADROP-E-P
Gate profile size	Min 40 mm
Housing	Anodized aluminium
Cylinder	Half Euro-cylinder (included)
Electrical specifications	U=24VDC±20%; IMAX=2.2A; P=20mW/55W (MAX)
Fixation	Quick-Fix (2x)
Weather resistance	IP66
Colour	Black / Silver
Warranty	2 years
Power supply	PowerStone - 24V DC 60W



SCAN FOR
MORE INFO

ELECTRADROP-R



500 K CYCLES

STAINLESS MATERIAL

PREMIUM QUALITY



LOCINOX[®]

Let's make it better together

Motorised drop bolt with Fail Open functionality

Electric 24V drop bolt with 120 mm throw and integrated emergency batteries for safe opening of automated swing gates.

By securing your gate with an Electradrop you disburden the electric gate motors.



Find out more: locinox.com | help@locinox.com

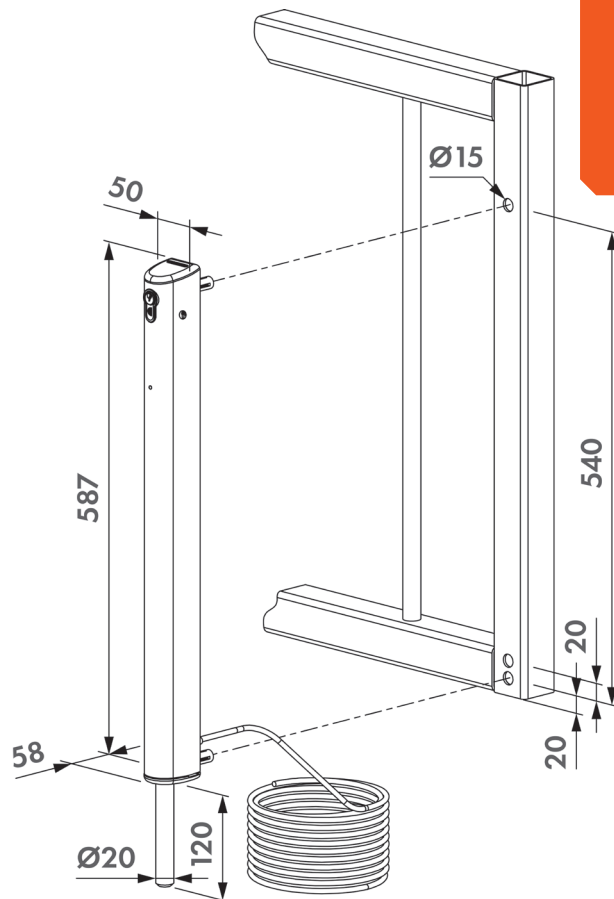

LOCINOX

Electradrop-R

Motorised drop bolt with
Fail Open functionality

What makes it special?

- Automatic lift of the dropbolt by integrated battery pack in case of power failure
- Vandal-proof, powder coated aluminium housing
- To be connected to the Flashlight output connector of the motor controller of an automatic gate (Min 3 sec preflash)
- Automatic detection and memorisation of the continuous or pulse signal
- Mechanical release possible (by key) in case of emergency
- The integrated obstacle detection will automatically stop the drop bolt movement in case of overpressure to avoid injuries.
- Throw: 120 mm
- Drop bolt diameter: 20 mm
- 5 m cable included
- Included: 3012-37-STD cylinder



Features

Configurations	ELECTRADROP-R ELECTRADROP-R-P
Gate profile size	Min 40 mm
Housing	Anodized aluminium
Cylinder	Half Euro-cylinder (included)
Electrical specifications	U=24VDC±20%; IMAX=2.2A; P=20mW/55W (MAX)
Fixation	Quick-Fix (2x)
Weather resistance	IP66
Colour	Black / Silver
Warranty	2 years
Power supply	PowerStone - 24V DC 60W
Battery lifetime	>300 bolt movements on batteries with 10 years battery lifetime